

808nm 10W-15W High Power Fiber Bundled Diode Lasers

K808F02MN-10.00W K808F02MN-15.00W

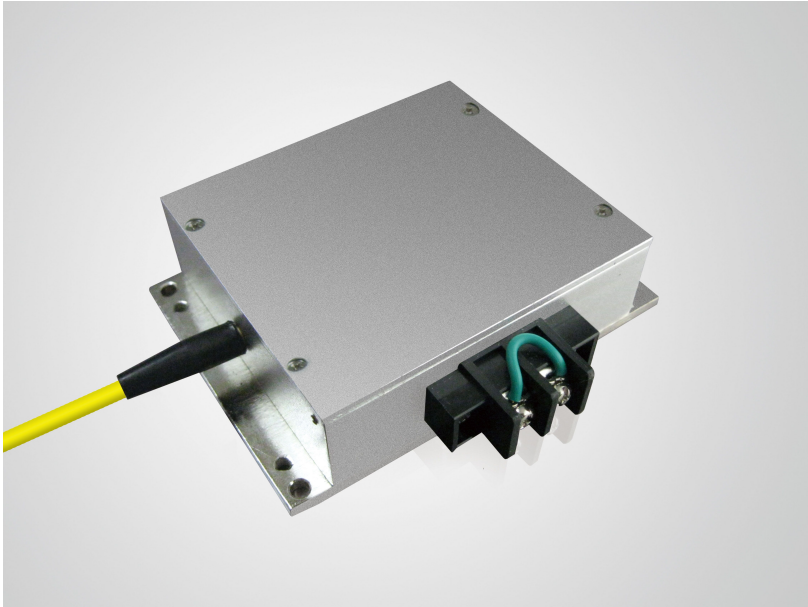

Features:

- ◆ 10W, 15W output power
- ◆ 375 μ m fiber bundle diameter
- ◆ 0.22N.A.
- ◆ 808nm wavelength
- ◆ 650nm aiming beam optional

Applications:

- ◆ Laser pumping
- ◆ Illumination
- ◆ Medical use
- ◆ Material processing

BWT Beijing's High Power Diode Laser Modules are manufactured by adopting specialized fiber-coupling techniques, resulting in volume products with a high efficiency, stability and superior beam quality. The products are achieved by transforming the asymmetric radiation from the laser diode chip into an output fiber with small core diameter by using special micro optics. Inspecting and burn-in procedures in every aspect come to a result to guarantee each product with the reliability, stability and long lifetime.

Our research staffs are constantly improving and innovating the processing technology in the producing process, based on the professional knowledge and experience accumulated in long-terms. We are also continuously developing new products to meet customers' specific needs.

At BWT Beijing, to provide high quality products with reasonable price is our always goal.

808nm 10W-15W High Power Fiber Bundled Diode Lasers

K808F02MN-10.00W K808F02MN-15.00W

Specifications (25°C)		Symbol	Unit	K808F02MN-10.00W	K808F02MN-15.00W
Optical Data	CW-Output Power ⁽¹⁾	P _O	W	10	15
	Center Wavelength	λ _c	nm	808	
	Tolerance of λ	-	nm	±3, ±10	
	Temperature Drift of λ	-	nm/°C	~0.3	
Fiber Data ⁽²⁾	Fiber Core Diameter	W _c	μm	375	
	Numerical Aperture	N.A.	-	0.22	
	Fiber Connector	-	-	SMA-905	
Electrical Data	Operating Current	I _{op}	A	2.6	3.0
	Threshold Current	I _{th}	A	0.4	
	Conversion Efficiency	η	%	40	
	Slope Efficiency	η _D	W/A	4.7	6.6
	Operating Voltage	V _{op}	V	~10.0	~14.0
	Reverse Voltage	V _{re}	V	~10.0	~14.0
Other	Operating Temperature	T _{op}	°C	10~30	
	Storage Temperature	T _{st}	°C	-20~+80	
	Expected Lifetime	MTTF	h	>10,000	
	Dimensions (fiber and connector not included)	-	mm	123×80×25	
	Weight	-	g	~600	

(1) All LDs inside are connected in serial.

(2) Other fibers available upon available.

808nm 10W-15W High Power Fiber Bundled Diode Lasers
K808F02MN-10.00W K808F02MN-15.00W

Characteristics

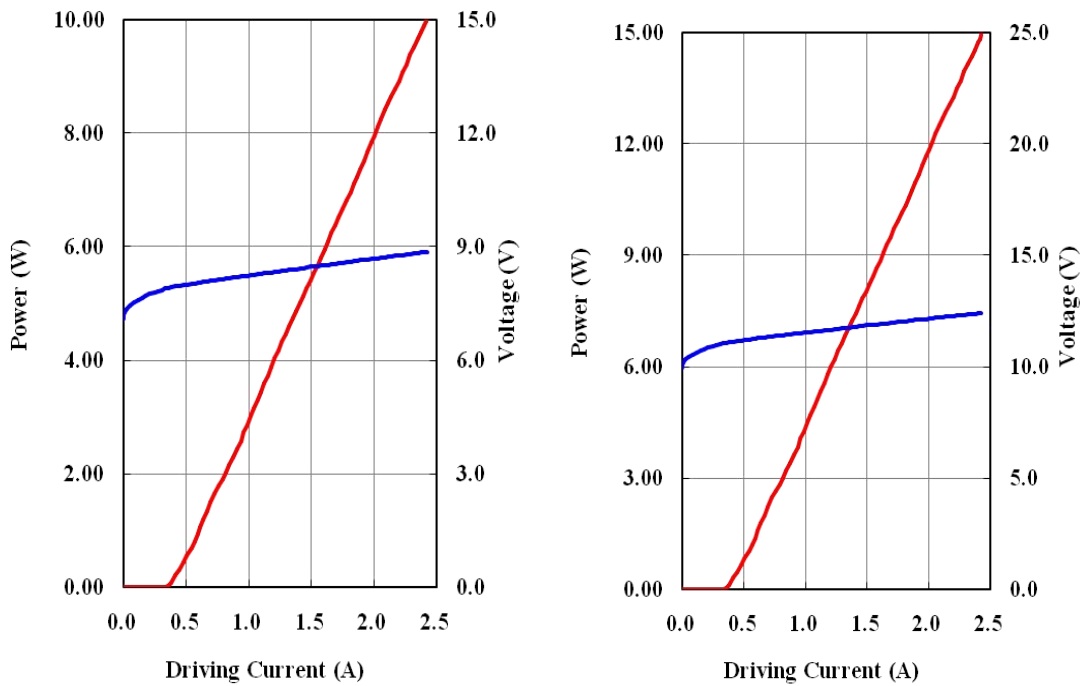

Typ. spectrum(T=25°C)

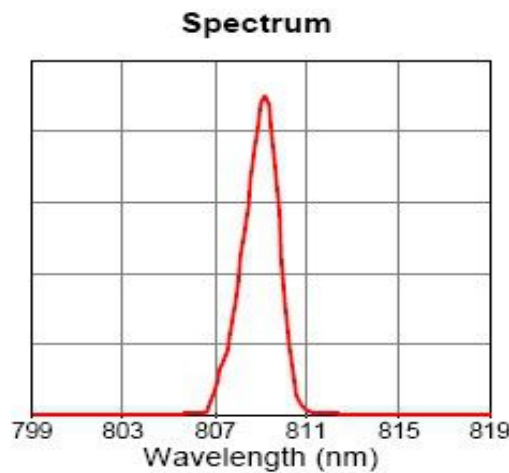

808nm 10W-15W High Power Fiber Bundled Diode Lasers

K808F02MN-10.00W K808F02MN-15.00W

Package Dimensions (mm)

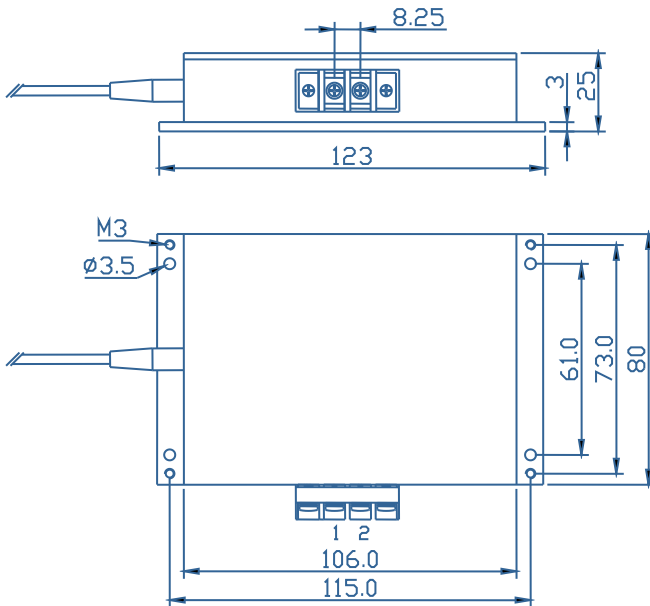

Pins	Function
1	LD (+)
2	LD (-)

OPERATING NOTES

- ◆ Avoid eye exposure to direct or scattered radiation.
- ◆ ESD precautions must be taken.
- ◆ Use constant current power supply. Avoid surge current.
- ◆ Laser diode must be used according to the specifications.
- ◆ Laser diode must work with good cooling.
- ◆ A minimum bend diameter should be 300 times greater than the fiber diameter.
- ◆ Operation temperature is 10°C~ 30°C.
- ◆ Storage: -20°C~ +80°C, all pins short-circuit.

